

MAINBOARD

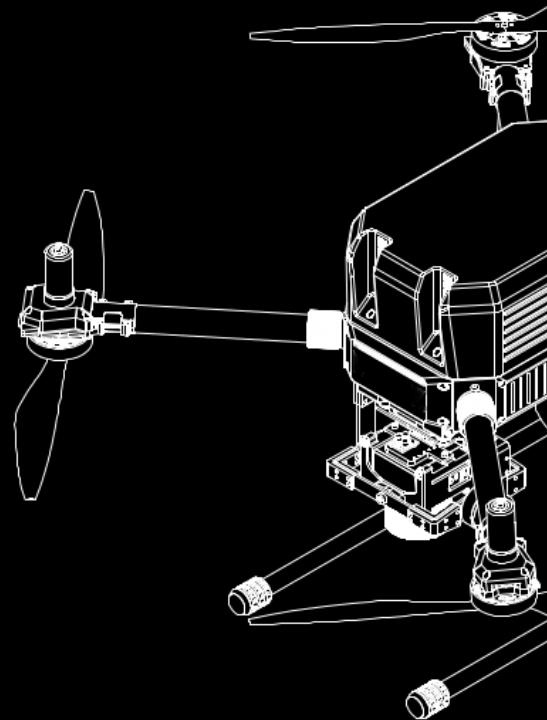

VIADRONE

DEV BOARD

- ▶ **SUPERB INTER-COMPONENT COMMUNICATION**
- ▶ **BETTER VIBRATION HANDLING**
- ▶ **EASY INTEGRATION**
- ▶ **REDUCED WIRING**

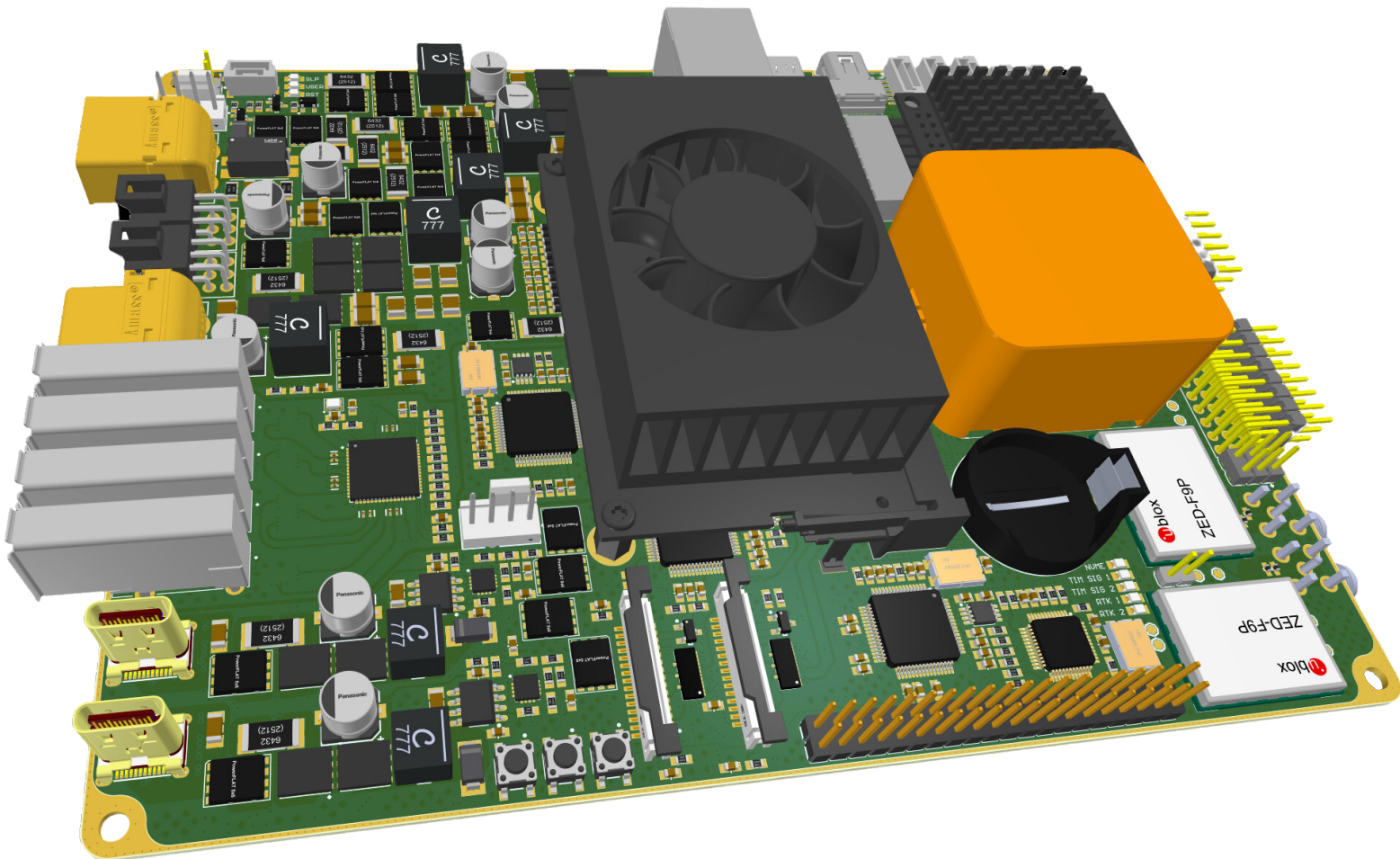

DEV BOARD IO

- ▶ COMPATIBLE WITH CUBE PILOT
- ▶ COMPATIBLE WITH JETSON NANO/XAVIER NX
- ▶ 2x CAN with 12V/8A OUT
- ▶ AUXILARY 12V/12A XT60 OUT
- ▶ 2x USB PD 5V,9V,12V,15V 3A USB-C (USB 2.0 ONLY)
- ▶ COMPATIBLE WITH RFD RADIO
- ▶ ETHERNET AND DISPLAY PORT FOR JETSON
- ▶ DEBUG USB-C

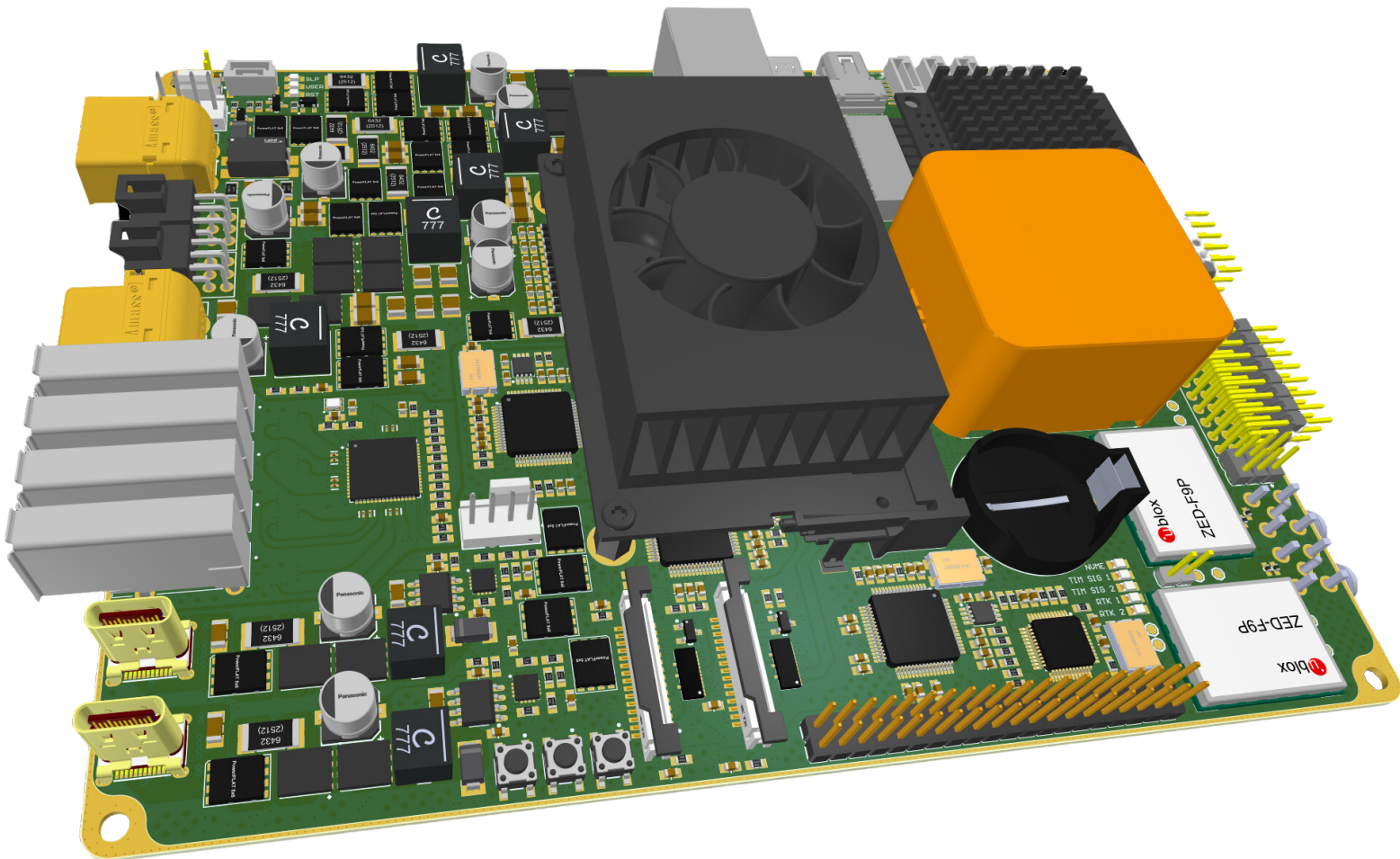

BLOCK DIAGRAM

